

PHILIPS 797A ALL-WAVE SET

CIRCUIT.—A five-valve A.C. mains superhet operating on short waves from 16-50 metres and on the usual medium and long waves.

Aerial signals are fed to V1, the frequency changer, through an inductively and capacitatively coupled band-pass filter and a small resistance in series with the grid to cut out parasitic oscillation on short waves.

Signals are fed to V2, an H.F. pentode, through an I.F. transformer tuned to 128 kc. The coupling between the windings of this transformer is manually variable, and is ganged with the tone control so that at the position of maximum selectivity the reproduction of the highest frequencies is at maximum.

A tuning indicator is connected in the anode lead of this valve.

The output of V2 is passed, via a second I.F. transformer, with fixed coupling to V3, a double-diode triode, which is volume controlled by R15. A fixed condenser C21 is connected in series with the slider and brought into operation by depression of the volume knob.

One diode of V3 is used to supply A.V.C. bias to the preceding valves in the orthodox manner.

The L.F. output of V3 is passed through a resistance and capacity stage to the output pentode V4, which is tone con-

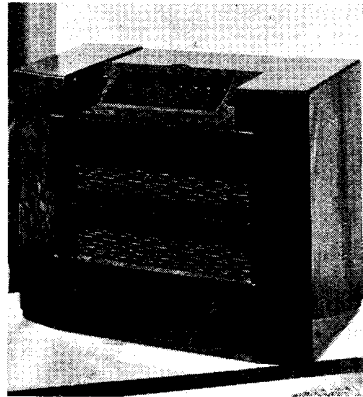

Audioscopic reproduction, Adaptor dial, automatic two-speed tuning, and finger-tip silencing are among the features of the distinctive Model 797A five-valve all-wave superhet marketed by Philips Lamps Ltd.

Below are the Philips chassis layout diagrams. That on the left gives the plan and that on the right the under-side view. The circuit and component values are on the facing page.

trolled in the grid circuit by C24 and R22.

Mains equipment consists of transformer, full-wave 1821 rectifier, smoothing choke, and electrolytic condensers.

Special Notes.—The dial lamps are the Philips type 8042. To remove them slacken the bolt in each end of the carrier, which will then pivot about the right-hand bolt, making the lamps easily accessible.

The tuning indicator lamp is a Philips 8041.

The external speaker is connected on the primary of the output transformer, and should have its own matching transformer.

The network, consisting of R27, R21, CK1 and CK2, is for balancing out certain distortion that might be introduced by the output valve. This is the basis of the "Audioscopic" reproduction.

R32 is fixed inside the connecting cap of V1.

Switching Explanation.—It will be seen there are two concentric rings of dots and circles in each switch diagram. The small circles represent contact springs on the stators, and the dots are used where there are no contacts.

The short radial lines between the two concentric rings represent shorting con-

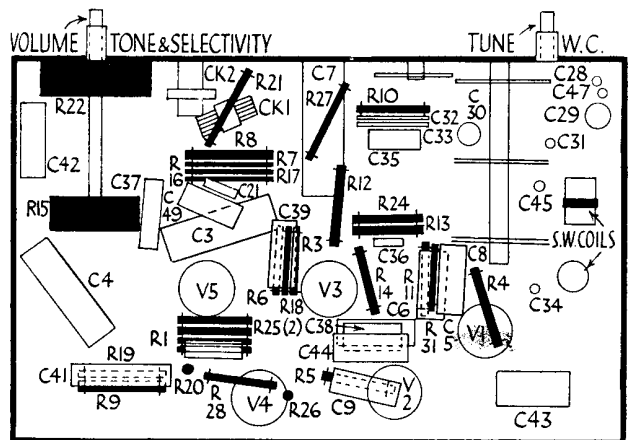
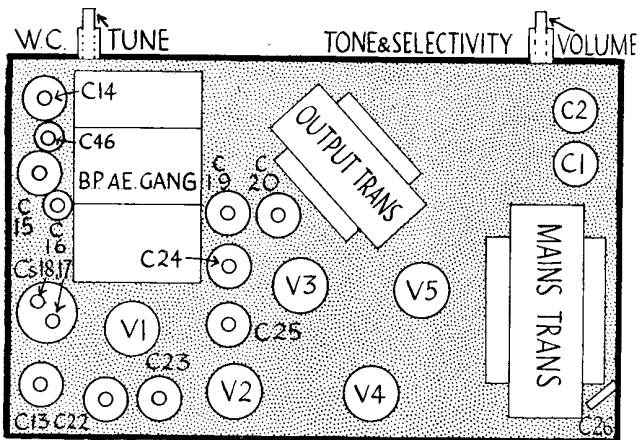

Service Sam
REPORTS:—

That kit of ERIE Resistors is certainly useful. ERIE put in just the values I always seem to want. You're right. You can't beat 'em!

Carded Kits of Erie Resistors, 24 popular assorted 1-watt values on card. Boxed Kits, containing 20 assorted 1-watt values. Each Resistor retails at 1/-



ERIE RESISTORS

- withstand all extremes of heat and damp.
 - Every possible value, 1 ohm to 40 megohms, 1/4, 1/2, 1, 2 and 3 watts.
- Erie INSULATED RESISTORS**
- 1/2 and 1 watt resistors available immediately in New Insulated Type.

PHILIPS 797A CIRCUIT AND COMPONENT VALUES

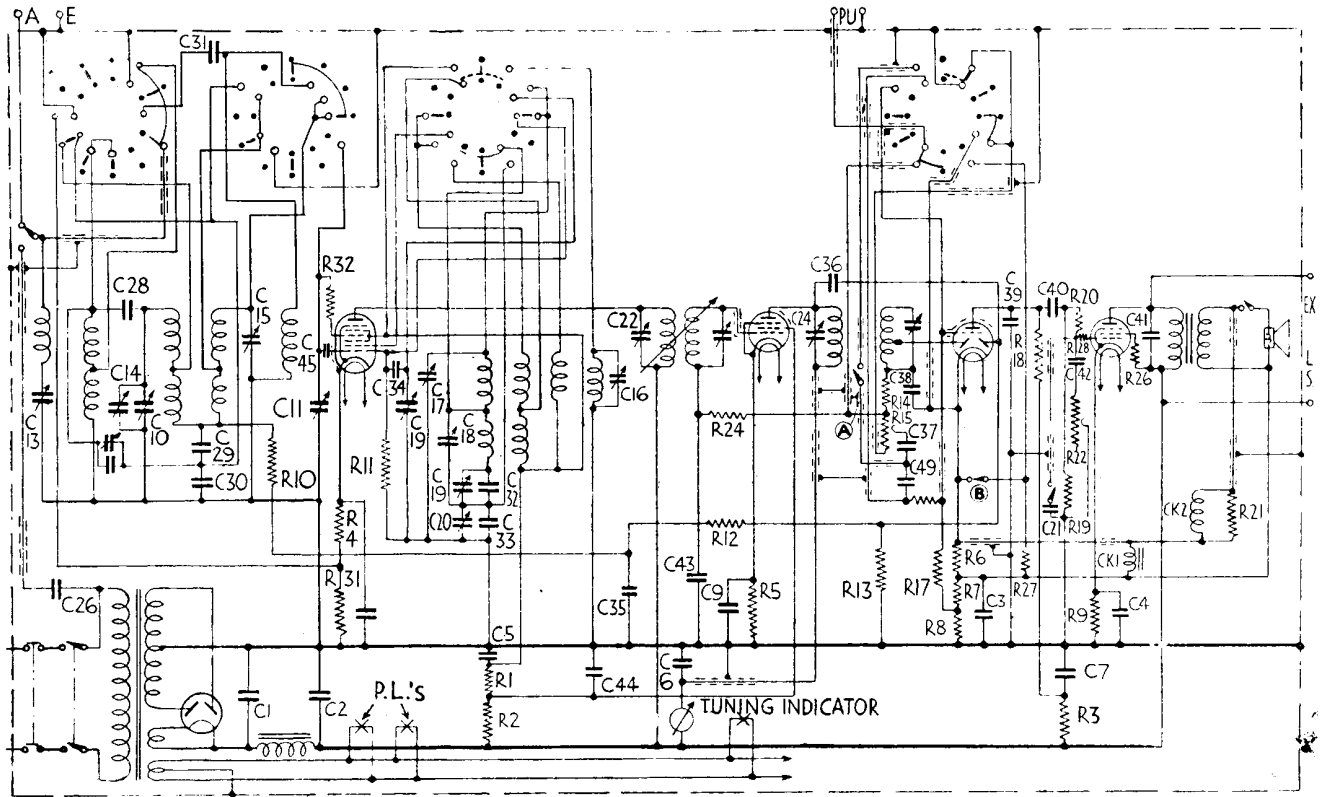

An explanation of the switching in the Philips circuit is given in the text matter. Switches A and B are shown in the "Radio" position.

VALVE READINGS

No signal. Volume maximum. 200v. A.C. mains

V.	Type.	Electr. pd.	Volts.	Ma.
1	Mullard FC4. Met. (7) ...	Anode	260	2.2
		Screen	70	2
		Osc. anode.	70	5
2	Mullard VP4B Met. (7) ...	Anode ...	240	6.5
		Screen	150	2.3
3	Mullard TDD4 Met (7) ...	Anode ...	70	1.
4	Mullard PenA4 (7) ...	Anode ...	250	34.
		Screen	260	3.9
5	Philips 1821 (4) ...	Filament	285	—

RESISTANCES

R. Purpose. Ohms.

R.	Purpose.	Ohms.
1	V1 osc. anode and screen decoupling	10,000
3	V3 anode decoupling	50,000
4	V1 cathode bias potentiometer.	250
5	V2 cathode bias	1,250
6	V3 bias network	32
7	V3 bias network	3,200
8	V3 bias network	4,000
9	V4 cathode bias	160
10	V1 A.V.C. decoupling	.1 meg
11	V1 osc. grid leak	50,000
12	V1 A.V.C. decoupling	.1 meg
13	A.V.C. diode load	.5 meg
14	Part demod. diode load	.1 meg
15	Volume control	.5 meg
16	V3 series grid	1.6 meg
17	V3 grid leak	1.6 meg
18	V3 anode load	.1 meg
19	V4 grid leak	.8 meg
20	V4 grid stopper	.1 meg
21	Audioscopic tone filter	500
22	Tone control	.04 + 2.5 + .04 meg
24	V2 A.V.C. decoupling	1.6 meg
25	V2 screen decoupling	1,250
26	V4 screen decoupling	32
27	Audioscopic tone filter	32
28	V4 grid stabiliser	1,000
31	V1 cathode bias potentiometer.	2,500
32	V1 grid stabiliser	50

CONDENSERS

C. Purpose. Mfd.

C.	Purpose.	Mfd.
1	H.T. smoothing	32
2	H.T. smoothing	32
3	V3 cathode bias shunt	25
4	V4 cathode bias shunt	25
5	V1 osc. anode and screen decoupling.	.1
6	V2 anode decoupling	.1
7	V3 anode decoupling	.5
8	V1 cathode bias shunt	.05
9	V2 cathode bias shunt	.1
21	Muting	.1
26	Mains aerial	.0005
28	Band pass coupling	.0001
29	V1 A.V.C. decoupling	.016
30	Band-pass coupling	.025
31	Short-wave coupling	.000016
32	Padding	.00065
33	Padding	.001375
34	V1 oscillator grid	.0001
35	V1 A.V.C. decoupling	.1
36	A.V.C. diode coupling	.00001
37	L.F. coupling	.01
38	H.F. by-pass	.0001
39	Anode shunt	.0004
40	L.F. coupling	.02
41	Pentode compensating	.004
42	Tone circuit	.008
43	V2 A.V.C. decoupling	.1
44	V2 screen decoupling	.1
45	Osc. regeneration control	.000002
47	Image suppressor	.0002
49	Speech L.F. coupling	.00025

tacts on the rotor. Where there is a solid line joining two or more of these short radial lines, the shorting contacts are actually connected together.

The dotted arcs show that adjacent contacts are shorted together (not permanently, but according to the position of the rotor).

The switches are shown in the open position. They work in a clockwise direction, the order of operation being : short, medium and long waves, gramophone. With each new position, of course, all the shorting strips move along one set of contacts clockwise.

Removing Chassis.—Practically all the work necessary on this receiver may be done without removing the chassis by

taking the fibre board from underneath the cabinet. This is secured by four screws.

Should it be found necessary to remove the chassis, the procedure is as follows: Remove the four knobs from the front of the cabinet (the two large knobs have two grub screws each) and the four bolts from underneath the cabinet.

Raise the scale assembly to the limit of its travel, release the dial lamp bracket

from its securing bolts, and holding the Bowden wire, slacken pointer screw.

Next free the cable to the wave-change indicator and completely unscrew the hollow adjustment screw. Unscrew the two slotted nuts on either side at the bottom of the scale and remove the copper strips. The scale may then be removed.

This will leave the bracket supporting (Continued on page 47.)